

STUDBOLTS AND STUDS

ASME B16.5 / DIN976
DIN 835 / DIN938 / DIN939
DIN 940 / BS4439
DIN2510

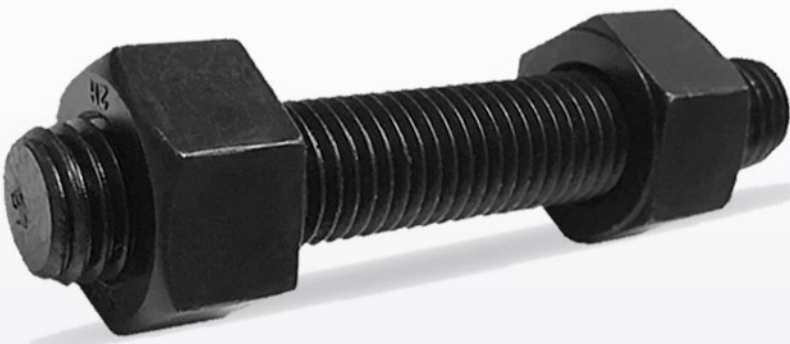

INDEX

PAGE	CONTENT
2	Index
3	Studbolts (Imperial) - ASME B16.5
4	Studbolts (Metric) - DIN976
5	Engineer Studs - DIN835 (Metal End = 2xD)
6	Engineer Studs - DIN938 (Metal End = 1xD)
7	Engineer Studs - DIN939 (Metal End = 1.25xD)
8	Engineer Studs - DIN940 (Metal End = 2.5xD)
9	Engineer Studs - BS4439 (Metal End = 1xD)
10	Studs with Reduced Shank - DIN2510-L
11	Studs with Reduced Shank - DIN2510-K (Short Thread)
12	Studs with Reduced Shank - DIN2510-Z (Long Thread)
13	Studs with Reduced Shank - DIN2510-KU (Short Thread & Spacer)
14	Studs with Reduced Shank - DIN2510-ZU (Long Thread & Spacer)
15	Standard Nuts - DIN2510-NF
16	Non-Standard Studs

STUDBOLTS (IMPERIAL) – ASME B16.5

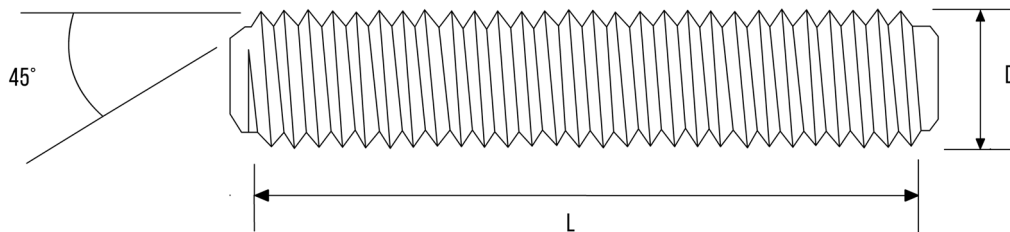

DIA (D)	TPI (UNC)	TPI (UNS)	DIA (D)	TPI (UNC)	TPI (UNS)
1/4"	0.25	20	1.1/2"	6	8
5/16"	0.3125	18	1.5/8"	-	8
3/8"	0.375	16	1.3/4"	5	8
7/16"	0.4375	14	1.7/8"	-	8
1/2"	0.50	13	2"	4.5	8
9/16"	0.5625	12	2.1/4"	4.5	8
5/8"	0.625	11	2.1/2"	4	8
3/4"	0.75	10	2.3/4"	4	8
7/8"	0.875	9	3"	4	8
1"	1.00	8	3.1/4"	4	8
1.1/8"	1.125	7	3.1/2"	4	8
1.1/4"	1.25	7	3.3/4"	4	8
1.3/8"	1.375	6	4"	4	8

- The length (L), measured parallel to the axis, is the distance from first thread to first thread
- End points are flat and chamfered both ends
- Length of point on studbolts shall be not less than one nor more than two complete threads as measured from the extreme end parallel to the axis
- Threads are UNC for all studbolt diameters 1" and smaller
- Threads are UNS for all studbolt diameters 1.1/8" and above. These can be supplied as UNC but are non-standard.
- Threads are Class 2A for all studbolts in accordance with ASME B1.1

STUDBOLTS (METRIC) – DIN976

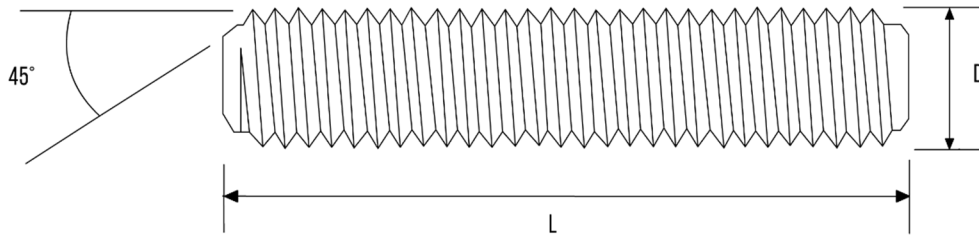

Diameter(D)	Pitch (Coarse)	Diameter(D)	Pitch (Coarse)
M6	1	M36	4
M8	1.25	M39	4
M10	1.5	M42	4.5
M12	1.75	M45	4.5
M14	2	M48	5
M16	2	M52	5
M18	2.5	M56	5.5
M20	2.5	M64	6
M22	2.5	M72	6
M24	3	M76	6
M27	3	M80	6
M30	3.5	M90	6
M33	3.5	M100	6

- The length (L), measured parallel to the axis, is the distance from end to end
- End points are flat and chamfered both ends
- Length of point on studbolts shall be not less than one nor more than two complete threads as measured from the extreme end parallel to the axis
- Threads are accordance with ISO 261

ENGINEER STUDS – DIN835 (METAL END = 2xD)

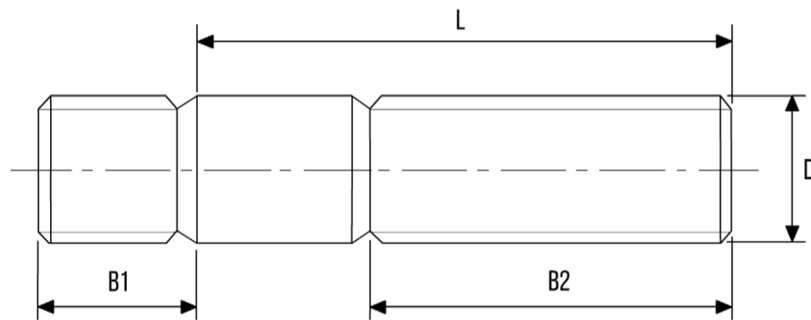

Diameter (D)	Pitch	Metal End 2Xd (B1)	Nut End (B2)		
			L ≤ 125	L = 125-200	L ≥ 200
M8	1.25	16	22	28	-
M10	1.50	20	26	32	45
M12	1.75	24	30	36	49
M14	2.00	28	34	40	53
M16	2.00	32	38	44	57
M18	2.50	36	42	48	61
M20	2.50	40	46	52	65
M22	2.50	44	50	56	69
M24	3.00	48	54	60	73
M27	3.00	52	60	66	79
M30	3.50	60	66	72	85
M33	3.50	66	72	78	91
M36	4.00	72	78	84	97
M39	4.00	78	84	90	103
M42	4.50	84	90	96	109
M45	4.50	90	98	102	115
M48	5.00	96	102	108	121
M52	5.00	65	110	116	129

- The length (L) is the nominal length of the stud. This is the length given when ordering.
- The overall length of the stud is the nominal length plus the length of the metal end (B1)
- Studs are manufactured to order and can be made in any material.

ENGINEER STUDS – DIN938 (METAL END = 1xD)

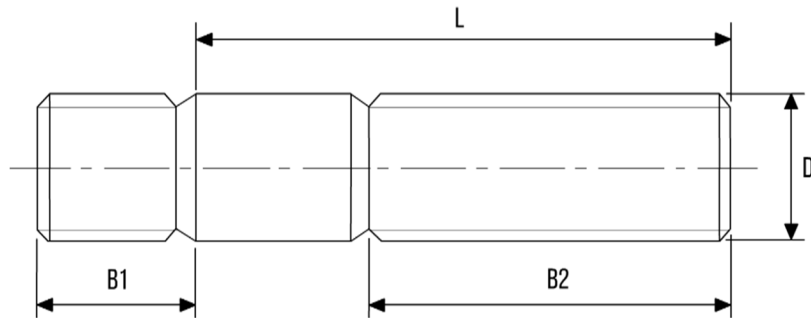

Diameter (D)	Pitch	Metal End 1xD (B1)	Nut End (B2)		
			L ≤ 125	L = 125-200	L ≥ 200
M8	1.25	8	22	28	-
M10	1.50	10	26	32	45
M12	1.75	12	30	36	49
M14	2.00	14	34	40	53
M16	2.00	16	38	44	57
M18	2.50	18	42	48	61
M20	2.50	20	46	52	65
M22	2.50	22	50	56	69
M24	3.00	24	54	60	73
M27	3.00	27	60	66	79
M30	3.50	30	66	72	85
M33	3.50	33	72	78	91
M36	4.00	36	78	84	97
M39	4.00	39	84	90	103
M42	4.50	42	90	96	109
M45	4.50	45	98	102	115
M48	5.00	48	102	108	121
M52	5.00	52	110	116	129

- The length (L) is the nominal length of the stud. This is the length given when ordering.
- The overall length of the stud is the nominal length plus the length of the metal end (B1)
- Studs are manufactured to order and can be made in any material.

ENGINEER STUDS – DIN939 (METAL END = 1.25xD)

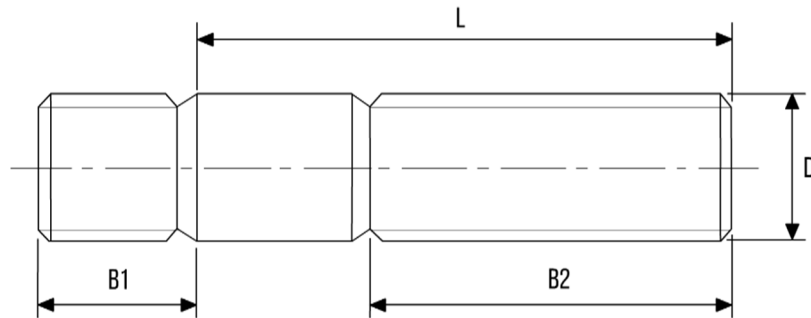

Diameter (D)	Pitch	Metal End 1.25xD (B1)	Nut End (B2)		
			L ≤ 125	L = 125-200	L ≥ 200
M8	1.25	10	22	28	-
M10	1.50	12	26	32	45
M12	1.75	15	30	36	49
M14	2.00	18	34	40	53
M16	2.00	20	38	44	57
M18	2.50	22	42	48	61
M20	2.50	25	46	52	65
M22	2.50	28	50	56	69
M24	3.00	30	54	60	73
M27	3.00	35	60	66	79
M30	3.50	38	66	72	85
M33	3.50	42	72	78	91
M36	4.00	45	78	84	97
M39	4.00	50	84	90	103
M42	4.50	52	90	96	109
M45	4.50	58	98	102	115
M48	5.00	60	102	108	121
M52	5.00	65	110	116	129

- The length (L) is the nominal length of the stud. This is the length given when ordering.
- The overall length of the stud is the nominal length plus the length of the metal end (B1)
- Studs are manufactured to order and can be made in any material.

ENGINEER STUDS – DIN940 (METAL END = 2.5xD)

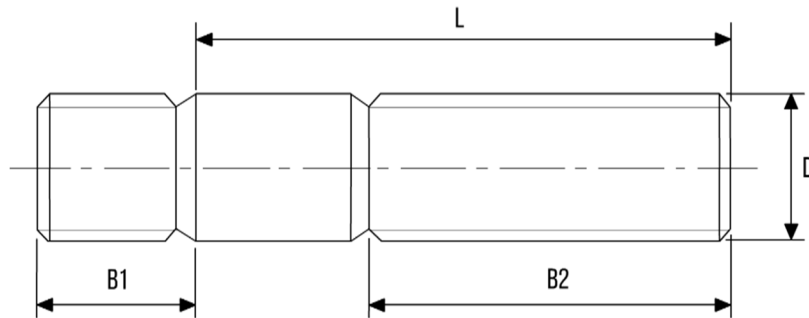

Diameter (D)	Pitch	Metal End 2.5xD (B1)	Nut End (B2)		
			L ≤ 125	L = 125-200	L ≥ 200
M8	1.25	20	22	28	-
M10	1.50	25	26	32	45
M12	1.75	30	30	36	49
M14	2.00	35	34	40	53
M16	2.00	40	38	44	57
M18	2.50	45	42	48	61
M20	2.50	50	46	52	65
M22	2.50	55	50	56	69
M24	3.00	60	54	60	73
M30	3.50	75	66	72	85
M36	4.00	90	78	84	97
M42	4.50	105	90	96	109
M48	5.00	120	102	108	121
M52	5.00	130	110	116	129

- The length (L) is the nominal length of the stud. This is the length given when ordering.
- The overall length of the stud is the nominal length plus the length of the metal end (B1)
- Studs are manufactured to order and can be made in any material.

ENGINEER STUDS – BS4439 (METAL END = 1xD)

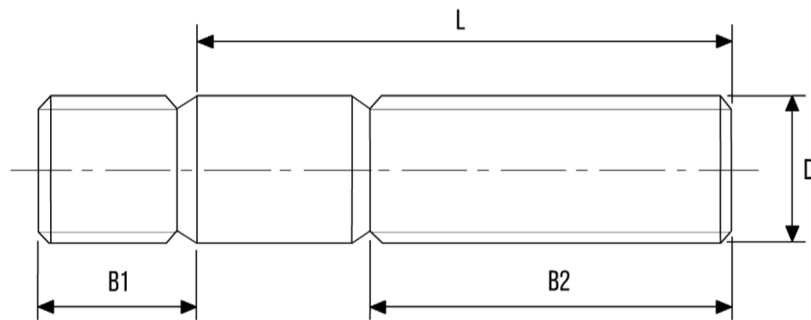

Diameter (D)	Pitch	Metal End 1xD (B1)	Nut End (B2)		
			L ≤ 125	L = 125-200	L ≥ 200
M8	1.25	8	22	28	-
M10	1.50	10	26	32	45
M12	1.75	12	30	36	49
M14	2.00	14	34	40	53
M16	2.00	16	38	44	57
M18	2.50	18	42	48	61
M20	2.50	20	46	52	65
M22	2.50	22	50	56	69
M24	3.00	24	54	60	73
M27	3.00	27	60	66	79
M30	3.50	30	66	72	85
M33	3.50	33	72	78	91
M36	4.00	36	78	84	97
M39	4.00	39	84	90	103
M42	4.50	42	90	96	109
M45	4.50	45	98	102	115
M48	5.00	48	102	108	121
M52	5.00	52	110	116	129

- The length (L) is the nominal length of the stud. This is the length given when ordering.
- The overall length of the stud is the nominal length plus the length of the metal end (B1)
- Studs are manufactured to order and can be made in any material.

STUDS WITH REDUCED SHANK - DIN2510-L

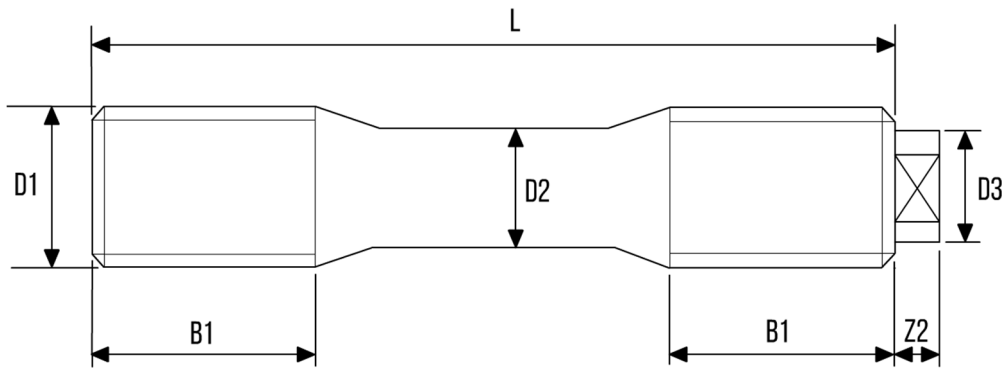

D1 (Diameter)	Pitch	D2	D3	B1	Z2
M12	1.75	8.5	8.0	20.0	4.0
M16	2.00	12.0	12.0	23.0	5.0
M20	2.50	15.0	14.0	28.0	6.0
M24	3.00	18.0	14.0	32.0	6.0
M27	3.00	20.5	18.0	35.0	6.0
M30	3.50	23.0	18.0	39.0	6.0
M33	3.50	25.5	25.0	42.0	9.0
M36	4.00	27.5	25.0	45.0	9.0
M39	4.00	30.5	28.0	48.0	10.0
M42	4.50	32.5	28.0	52.0	10.0
M45	4.50	35.5	32.0	55.0	11.0
M48	5.00	37.5	32.0	58.0	11.0
M52	5.00	41.0	36.0	62.0	12.0
M56	5.50	44.0	40.0	-	13.0

- DIN2510 Studs are manufactured to order and can be made in any material.
- DIN2510 Studs are generally supplied with DIN2510 NF Nuts (Shown on page 15)

STUDS WITH REDUCED SHANK - DIN2510-K (SHORT THREAD)

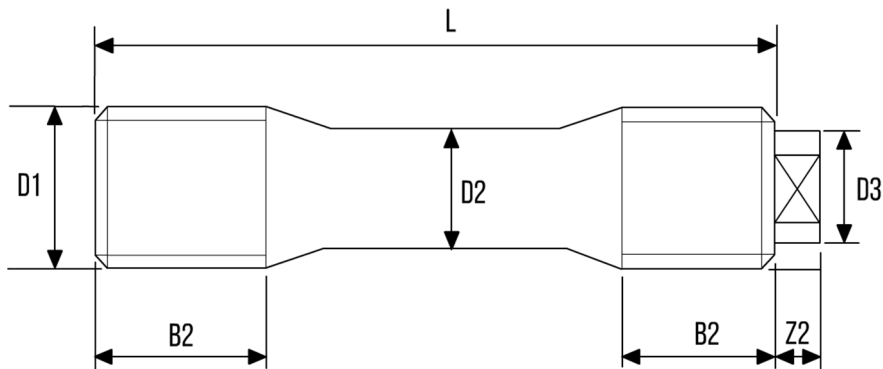

D1 (Diameter)	Pitch	D2	D3	B2	Z2
M12	1.75	8.5	8.0	13.0	4.0
M16	2.00	12.0	12.0	16.0	5.0
M20	2.50	15.0	14.0	20.0	6.0
M24	3.00	18.0	14.0	24.0	6.0
M27	3.00	20.5	18.0	27.0	6.0
M30	3.50	23.0	18.0	30.0	6.0
M33	3.50	25.5	25.0	33.0	9.0
M36	4.00	27.5	25.0	36.0	9.0
M39	4.00	30.5	28.0	39.0	10.0
M42	4.50	32.5	28.0	42.0	10.0
M45	4.50	35.5	32.0	45.0	11.0
M48	5.00	37.5	32.0	48.0	11.0
M52	5.00	41.0	36.0	52.0	12.0
M56	5.50	44.0	40.0	56.0	13.0

- DIN2510 Studs are manufactured to order and can be made in any material.
- DIN2510 Studs are generally supplied with DIN2510 NF Nuts (Shown on page 15)

STUDS WITH REDUCED SHANK - DIN2510-Z (LONG THREAD)

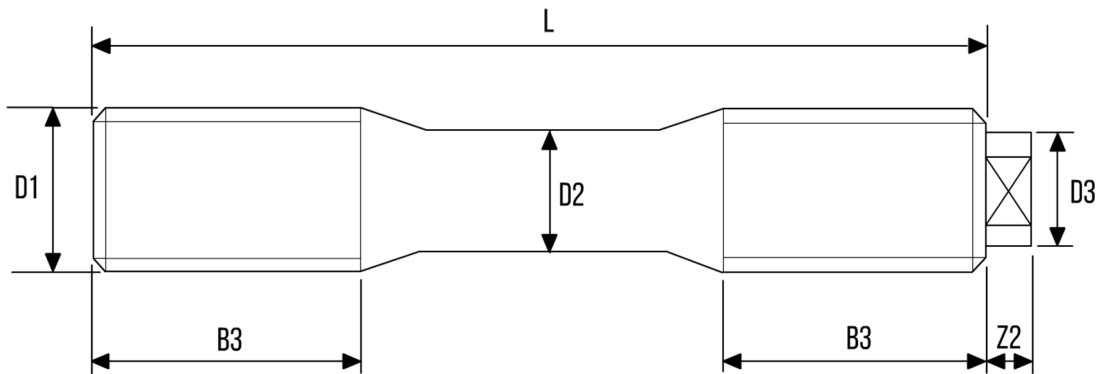

D1 (Diameter)	Pitch	D2	D3	B3	Z2
M12	1.75	8.5	8.0	27.0	4.0
M16	2.00	12.0	12.0	31.0	5.0
M20	2.50	15.0	14.0	36.0	6.0
M24	3.00	18.0	14.0	42.0	6.0
M27	3.00	20.5	18.0	47.0	6.0
M30	3.50	23.0	18.0	50.0	6.0
M33	3.50	25.5	25.0	53.0	9.0
M36	4.00	27.5	25.0	57.0	9.0
M39	4.00	30.5	28.0	60.0	10.0
M42	4.50	32.5	28.0	64.0	10.0
M45	4.50	35.5	32.0	66.0	11.0
M48	5.00	37.5	32.0	70.0	11.0
M52	5.00	41.0	36.0	74.0	12.0
M56	5.50	44.0	40.0	79.0	13.0

- DIN2510 Studs are manufactured to order and can be made in any material.
- DIN2510 Studs are generally supplied with DIN2510 NF Nuts (Shown on page 15)

STUDS WITH REDUCED SHANK - DIN2510-KU (SHORT THREAD & SPACER)

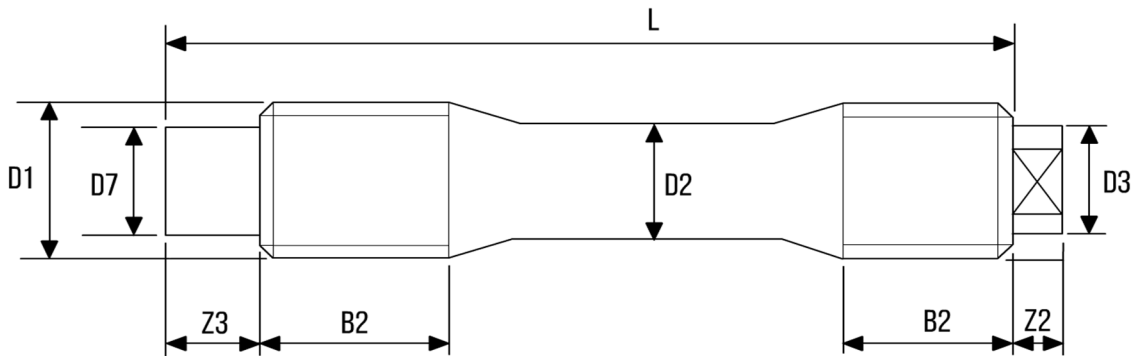

D1 (Diameter)	Pitch	D2	D3	D7	B2	Z2	Z3
M12	1.75	8.5	8.0	8.0	13.0	4.0	11.0
M16	2.00	12.0	12.0	12.0	16.0	5.0	14.0
M20	2.50	15.0	14.0	13.0	20.0	6.0	16.0
M24	3.00	18.0	14.0	16.0	24.0	6.0	17.0
M27	3.00	20.5	18.0	18.0	27.0	6.0	19.0
M30	3.50	23.0	18.0	21.0	30.0	6.0	19.0
M33	3.50	25.5	25.0	24.0	33.0	9.0	21.0
M36	4.00	27.5	25.0	26.0	36.0	9.0	23.0
M39	4.00	30.5	28.0	30.0	39.0	10.0	23.0
M42	4.50	32.5	28.0	32.0	42.0	10.0	24.0
M45	4.50	35.5	32.0	34.0	45.0	11.0	25.0
M48	5.00	37.5	32.0	37.0	48.0	11.0	26.0
M52	5.00	41.0	36.0	40.0	52.0	12.0	26.0
M56	5.50	44.0	40.0	45.0	56.0	13.0	28.0

- DIN2510 Studs are manufactured to order and can be made in any material.
- DIN2510 Studs are generally supplied with DIN2510 NF Nuts (Shown on page 15)

STUDS WITH REDUCED SHANK - DIN2510-ZU (LONG THREAD & SPACER)

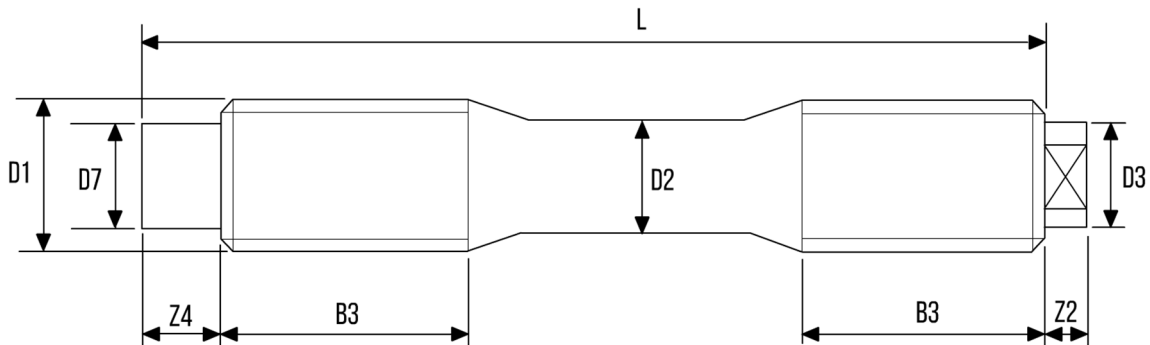

D1 (Diameter)	Pitch	D2	D3	D7	B3	Z2	Z4
M12	1.75	8.5	8.0	8.0	27.0	4.0	7.0
M16	2.00	12.0	12.0	12.0	31.0	5.0	8.0
M20	2.50	15.0	14.0	13.0	36.0	6.0	9.0
M24	3.00	18.0	14.0	16.0	42.0	6.0	8.0
M27	3.00	20.5	18.0	18.0	47.0	6.0	10.0
M30	3.50	23.0	18.0	21.0	50.0	6.0	12.0
M33	3.50	25.5	25.0	24.0	53.0	9.0	12.0
M36	4.00	27.5	25.0	26.0	57.0	9.0	14.0
M39	4.00	30.5	28.0	30.0	60.0	10.0	14.0
M42	4.50	32.5	28.0	32.0	64.0	10.0	15.0
M45	4.50	35.5	32.0	34.0	66.0	11.0	15.0
M48	5.00	37.5	32.0	37.0	70.0	11.0	19.0
M52	5.00	41.0	36.0	40.0	74.0	12.0	18.0
M56	5.50	44.0	40.0	45.0	79.0	13.0	19.0

- DIN2510 Studs are manufactured to order and can be made in any material.
- DIN2510 Studs are generally supplied with DIN2510 NF Nuts (Shown on page 15)

STANDARD NUTS - DIN2510-NF

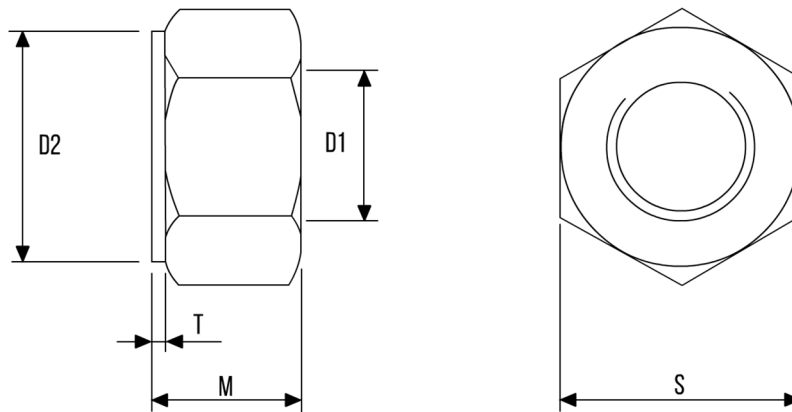

D1 (Diameter)	Pitch	D2	M	T	S
M12	1.75	21.0	12.0	2.0	22.0
M16	2.00	26.0	16.0	2.0	27.0
M20	2.50	31.0	20.0	2.0	32.0
M24	3.00	35.0	24.0	3.0	36.0
M27	3.00	40.0	27.0	3.0	41.0
M30	3.50	45.0	30.0	3.0	46.0
M33	3.50	49.0	33.0	3.0	50.0
M36	4.00	53.5	36.0	3.0	55.0
M39	4.00	58.5	39.0	3.0	60.0
M42	4.50	63.5	42.0	3.0	65.0
M45	4.50	68.5	45.0	3.0	70.0
M48	5.00	73.5	48.0	4.0	75.0
M52	5.00	78.5	52.0	4.0	80.0
M56	5.50	83.5	56.0	4.0	85.0

- DIN2510-NF is the standard form of nut to suit DIN2510 studs.
- Some materials are available as standard but other materials are manufactured to suit stud material.

NON-STANDARD STUDS

As well as all the ANSI, BS and DIN standard studs, we can supply any type of stud that is made to order. These are usually manufactured to a drawing or to suit the customer's specific requirements. Some examples of some of the non-standard studs we have supplied are shown below.

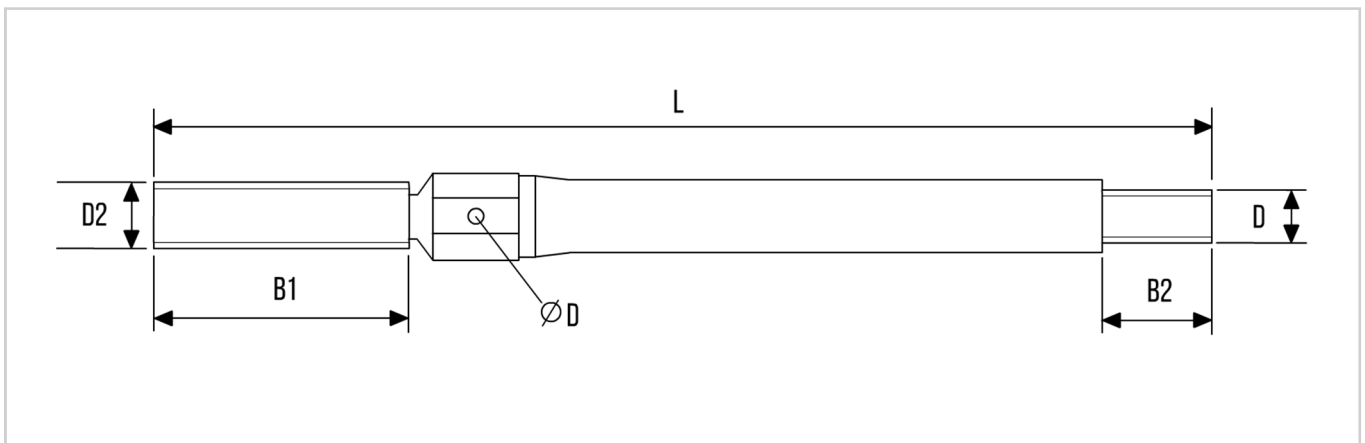
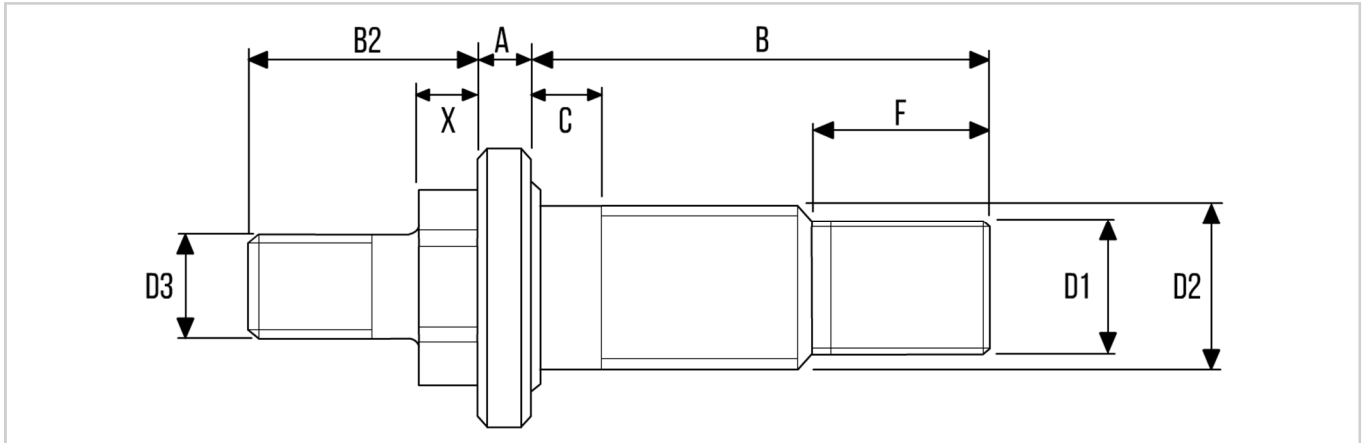
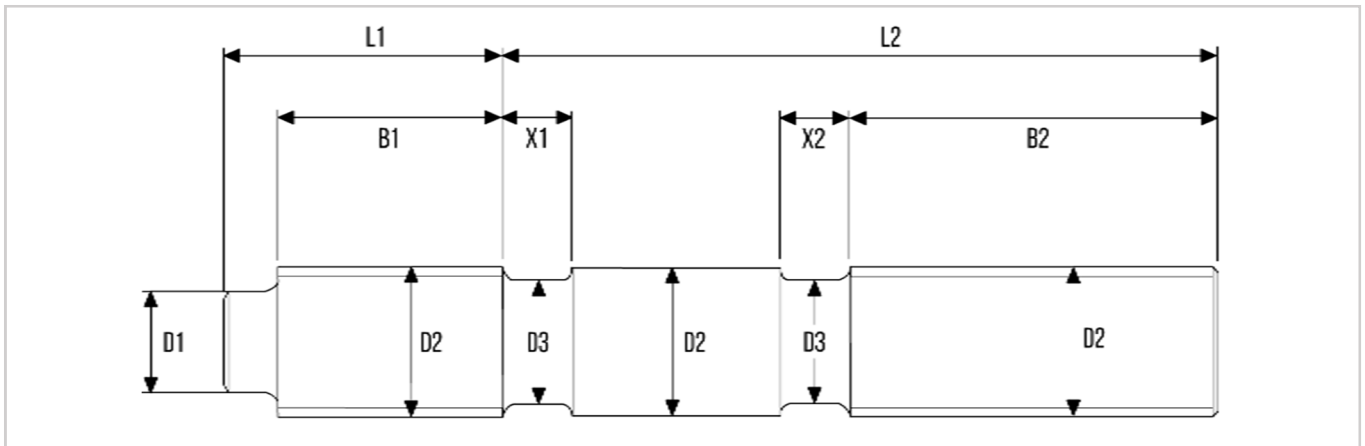

STUDBOLT 
SCOTLAND LIMITED
PETROCHEMICAL AND INDUSTRIAL GRADE FASTENERS AND SUPPLIES



www.studboltscotland.co.uk



8 Abbotsinch Road
Grangemouth
FK3 9UX



sales@studboltscotland.co.uk



01324 473355